



High Performance Films

DuPont FEP

fluorocarbon film

Techniques for Fabricating DuPont FEP Film

Introduction

DuPont FEP fluorocarbon film offers the outstanding properties of Teflon® in a convenient, easy-to-use form. The film is used “as received” in a number of applications. However, in many instances, the film must be fabricated into a product suitable for a specific application. Some examples would be:

- Metallizing the film to produce a substrate for flexible printed circuits
- Sealing the film to produce a bag or pouch
- Melt bonding the film to a metal substrate
- Using the film as a melt adhesive to bond two pieces of copper tubing
- Adhesive bonding the film to vinyl sheeting (laminating)
- Thermoforming the film into useful shapes such as corrosion-resistant labware (funnels, beakers, etc.)

This brochure will describe the techniques employed in fabricating DuPont FEP films. The following topics will be covered:

- Heat sealing
- Heat bonding
- DuPont FEP film as an adhesive
- Adhesive laminating
- Metallizing
- Thermoforming

Note that all of the information in this brochure is related to techniques for the fabrication of DuPont FEP films. The techniques for fabricating DuPont PFA film are very similar to those for DuPont FEP. The major difference is in the melting behavior of these films. DuPont PFA film melts about 28–42°C (50–75°F) higher than DuPont FEP. In all procedures requiring the film to be in the formable or melted state, equipment temperature should be modified accordingly. Procedures not requiring the DuPont PFA films to be formable or melted would be the same as for DuPont FEP films.

Heat Sealing Principles

In many areas of application, the heat sealability of DuPont FEP fluorocarbon film will be of interest as a method of fabrication. This section discusses some of the methods that may be employed to obtain heat seals with Types A and L films.

General

DuPont FEP film may be heat sealed by any method that heats the contacting surfaces of the film above the melt temperature of the polymer and, at the same time, provides intimate contact of those surfaces.

A fusion heat seal of DuPont FEP film is a non-peeling type of seal, and a wide seal area is not necessary. Better appearing seals with minimum distortion and puckering of the film are obtained

by localizing the heat applied to the film to as small an area as is practical. The use of hot bar or impulse sealing equipment necessitates bringing the entire thickness of film to the melting point of the polymer in order to accomplish a fusion temperature at the film interfaces. With relatively thin films, heat transfer time is sufficiently short to allow this method, although thinning out of the film adjacent to the seal occurs to a greater extent as film thickness increases. In continuous band sealing, this is accomplished by heating only the center portion of the band and by cooling the seal under pressure. Hot air sealing reduces thinning out by allowing the force of the air flow to act as the pressure medium and metal plates or guides to keep the majority of the film below the distortion temperature. Heat seals made with Type L FEP and Type LP PFA tend to be more durable.

Because molten DuPont FEP fluorocarbon film has a tendency to stick to the jaws of a heat sealer, it is desirable to use a release agent in the sealing operation. Kapton® polyimide film may also be used as a release slip sheet.

Hot Bar Heat Sealing

The use of hot bar sealing equipment having a minimum temperature capability of 288°C (550°F) and a fast recovery rate will give a wide seal area and be limited to a straight seal. Because it is difficult to localize or isolate the film seal area, a degree of puckering takes place in thinner films. Thinning out will occur adjacent to the fusion area due to the jaw pressure when the film is in a fusion state. Because the equipment does not usually allow temperature cycling during the seal cycle, the film is taken from the jaws while in a molten state when film distortion is at a maximum.

The following graphs illustrate the time/temperature/pressure relationships encountered in hot bar sealing. These general relationships hold true for other heat sealing methods as well.

Temperature

Figure 1 illustrates the effect of bar temperature upon the seal strength of 5-mil DuPont FEP film at constant bar pressure and dwell time. Above a specific bar temperature (310°C [590°F] with this equipment) there is no significant change in the bond strength of the heat seal.

Figure 1. Effect of Bar Temperature Upon Seal Strength of DuPont FEP Film
Pressure

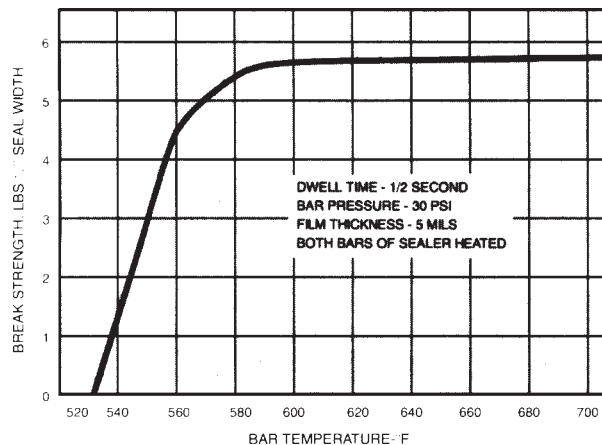

In **Figure 2**, data are plotted for bar pressures of 30 psi and 60 psi with 2-mil film and a constant dwell time of ¼ sec. Pressure appears to have no significant effect upon the bond strength of the fusion heat seals. However, certain qualifications should be made. First, in thicker gauge film (5-mil and greater), pressure does affect the minimum temperature at which a fusion heat seal can be made. Higher pressures tend to yield a fusion heat seal at a slightly lower bar temperature, probably due to the fact that higher pressures can improve the rate of heat transfer from the heated bar to the film. At high pressures, however, cut through and thinning out occur. DuPont FEP film possesses a relatively high melt viscosity, which is not nearly as much a problem as with lower melt viscosity thermoplastics.

Figure 2. Effect of Pressure Upon Seal Strength of DuPont FEP Film
Time

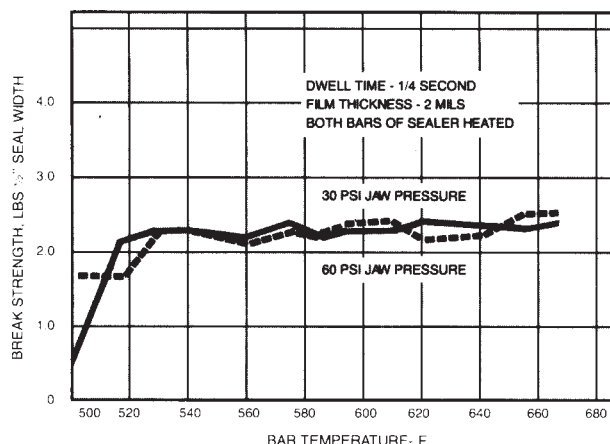
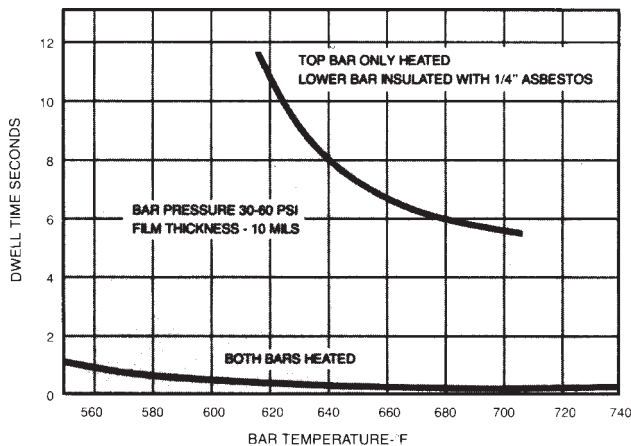

Figure 3 illustrates the considerable effect heating both bars vs. one bar of the sealer has upon the temperature-time relationship for obtaining a fusion heat seal. For example, at 338°C (640°F), it requires only 0.2 sec with two bars heated to obtain a fusion heat seal with 10-mil film, while with only one heated bar, 8.1 sec are required at this temperature. Theoretically, it should require four times as long to heat the film interfaces to the fusion temperature from one side as it should from both sides. However, lacking perfect insulation, heat losses to the surroundings and unheated bar increase this difference.

Figure 3. Effect of Bar Heating Upon Temperature-Time Relationship for Heat Sealing DuPont FEP Film



Figures 4 and 5 summarize the data obtained for heated bar sealing of DuPont FEP fluorocarbon film. **Figure 4** is for use when both bars are heated; **Figure 5** when only one bar is heated and the other one is insulated. In both figures, the selection of a temperature-dwell time combination above the indicated curve for a particular gauge film will result in a fusion heat seal of the selected gauge film.

In general, a selection of conditions just slightly in excess of the minimum indicated conditions should prove most satisfactory. This should minimize overheating and distortion of the film. The use of a different slip-sheet or different equipment may affect the selection of optimum temperature-dwell time conditions.

Figure 4. Temperature-Time Relationship for Obtaining Fusion Heat Seal with DuPont FEP Film

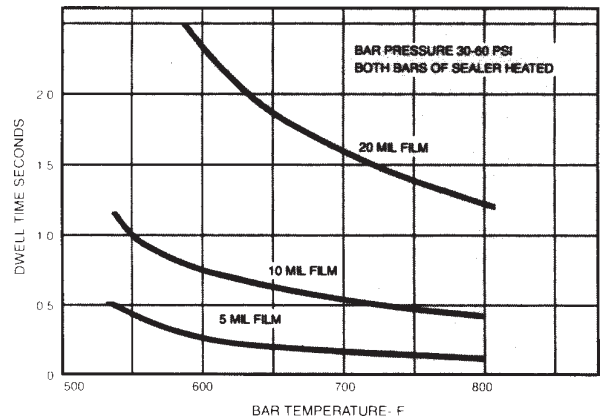
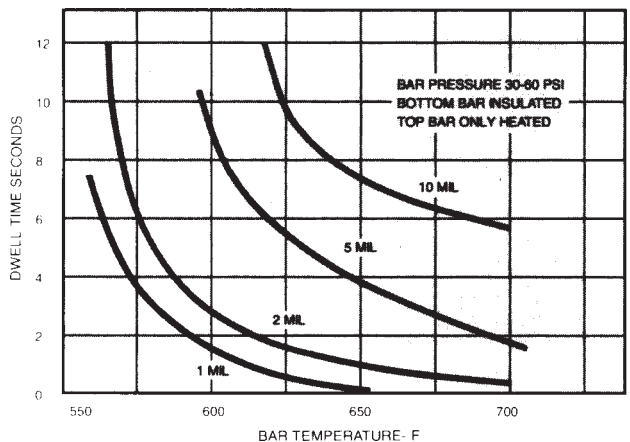

Figure 5. Temperature-Time Relationship for Obtaining Fusion Heat Seal with DuPont FEP Film



Effect of Gauge on Heat Seals

Figure 6 indicates the heat seal strength obtainable with the various gauges of DuPont FEP film. Because a DuPont FEP film fusion heat seal does not peel, the indicated break strength and elongation is that of the weakest link—the film just adjacent to the sealed area. In general, this is approximately 80% of the tensile strength and ultimate elongation of the virgin film.

Figure 6. Heat Seal Strength and Elongation Obtainable with DuPont FEP Film Compared to Virgin Film

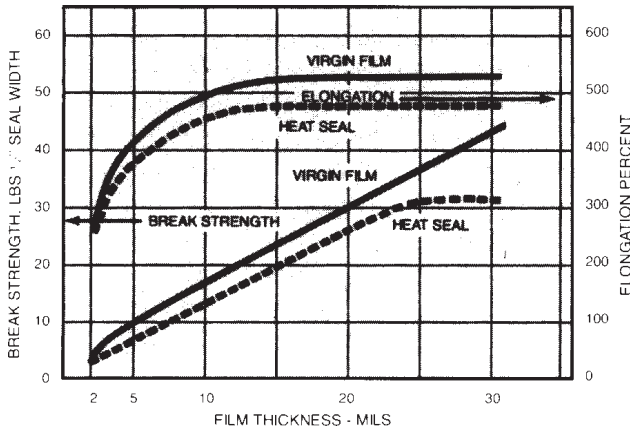

Impulse Heat Sealing

Vertrod Corp.* impulse heat sealing equipment has been used for DuPont FEP fluorocarbon film. The heat sealing is effected by a pulse of electrical current, which is passed through Nichrome** ribbons located in either top and/or bottom jaws. These ribbons transfer heat at a very high temperature for a short period of time. By varying the voltage and time of impulse with a jaw pressure of 10–25 psi, 1/2–20 mil DuPont FEP film may be sealed. The heavier gauges will usually require equipment modification.

The seal area will be the width of the Nichrome ribbons and, as with the hot bar sealer, will be limited to a straight seal. Thinning out at the edge of the seal will occur due to the thickness of the Nichrome ribbons and the molten state of the entire thickness of film when at the seal temperature. Because the Nichrome ribbons supply heat for only a short period of time, by allowing the seal to remain in the jaws for several seconds after the impulse, the seal will be cooled below its maximum distortion temperature before being removed. Some puckering will generally occur with thinner films because the seal area is not entirely isolated from the remainder of the film.

Shaped Seal

Curved or irregular sealing configurations that are not possible with hot bar or impulse sealing equipment may be made by using a heated metal shape such as a ring. However, special sealers for irregular shapes are commercially available. The metal shape must be capable of a minimum of 288°C (550°F) and preferably capable of higher temperatures to

allow a reasonably short seal cycle (considering the heat transfer time of the film and any slip sheet that may be used).

Care should be taken to ensure that the metal shape is not warped at the elevated sealing temperatures. Machining at these temperatures usually corrects this and allows for an even pressure and heating distribution.

In order to localize heat to the seal area only, cooled metal or nonmetal shapes may be placed in contact with the film area not being sealed. An insulation barrier should be placed between the heated and cooled shapes.

Sufficient contact time to allow the film interfaces to reach fusion temperature will depend upon the film thicknesses to be sealed and the temperature of the sealing mechanism. Heated metal shapes may be used on either one or both sides, both sides giving a faster heat transfer time and thus a shorter cycle.

A high-frequency generator may be used to heat, by induction techniques, a complex metal shape that cannot be heated by the use of conventional resistance type heater elements.

Hot Air Sealing

A hot air source may be used as a heat supply to seal DuPont FEP film. For relatively thick films (greater than 20 mil), a hot air stream may be directed at the interfaces of the film to be sealed while applying minimal pressure to provide intimate contact of those surfaces. This method provides heat only to the surfaces to be sealed and keeps the major portion of the film below distortion temperature.

Illustration A. Hot Air Sealing of Thick Films

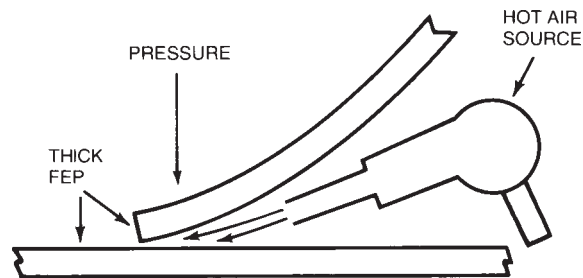

For thinner films where heat transfer time is sufficiently short, hot air may be applied to the outer surface of the film heating through the outer film layer to the interfaces and giving a fusion seal. If such a method is used, a metal guide should be

*Vertrod Corp., Brooklyn, NY

**Registered trademark of Driver Harris Company, Harrison, NJ

employed to keep the hot air stream directed to only the seal area, while the remainder of the film area is not exposed. A metal guide of complex shape will give a contour seal area.

Illustration B. Hot Air Sealing of Thin Films

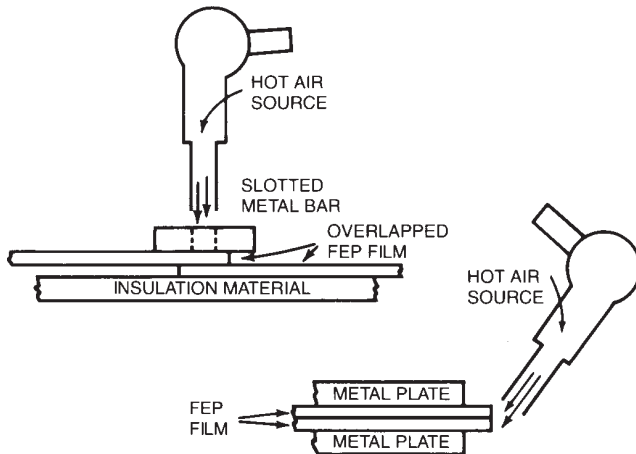

Thermoplastic Welding

This information is for experienced operators with a knowledge of thermoplastic welding techniques and a general awareness of available welding tools and equipment.

Publications about welding and fabricating thermoplastic materials may serve as an additional resource.

Safety

FEP fluorocarbon resin may undergo some decomposition at welding temperatures. Adequate ventilation must be provided with point-of-work exhaust hoods preferred. Individual fresh air masks may be necessary in some unavoidable enclosed spaces.

Further details regarding safety of DuPont FEP resin are contained in the bulletin, H-48633, "Guide to the Safe Handling of Fluoropolymer Resins, 2nd Edition," available from DuPont.

Materials and Equipment

Welding Rods should be extruded virgin FEP plastic, normally round, solid, and free of voids with a minimum diameter of $\frac{3}{32}$ in and a maximum of $\frac{3}{16}$ in.

Electrically Heated Welding Gun with at least a 750-W heating element capable of producing an air temperature of at least 427°C (800°F) when measured at a distance of $\frac{1}{4}$ in from the installed tip.

Inert Gas Supply and Pressure Regulator to provide 5–6 psig pressure at the tip of the welding tool.

Preparation

- Cleaning cannot be overemphasized. All surfaces, including welding rods and adjacent plastic for about 1 in beyond the joint, should be cleaned immediately prior to welding with a suitable solvent. **Do not use soap or detergents.**
- Beveling of thermoplastic edges is essential to obtain a satisfactory weld. Mechanically guided power tools should be used for straighter edges. Use these bevel angle guidelines for Teflon® FEP sheet:

– Butt Joints (single or double)	60°
– Corners	60°
– Fillets	45°
– Laps	Not required
- The joint must be kept in alignment during welding by mechanical clamping or tack welding with a maximum root gap of $\frac{1}{32}$ in.

Welding

- 1) Start hot gas welder at 343°C (650°F).
- 2) Preheat starting edge of joint material and rod until both appear shiny and become slightly tacky. Hold welding tip about $\frac{1}{4}$ in from weld joint/rod intersection.
- 3) Cut the end of the welding rod at a 45° angle, hold it at a 90° angle to the joint, and move it up and down slightly in the heat until it sticks to the base material. During continuous welding, a slight uniform motion of the torch between the sheet and rod is required (the standard Pendulum Technique used by the industry).
- 4) Holding the rod at a 45° angle with the base material, apply downward pressure on the rod of about 3 lb force. Avoid tension stretching of the rod. See sketch below.

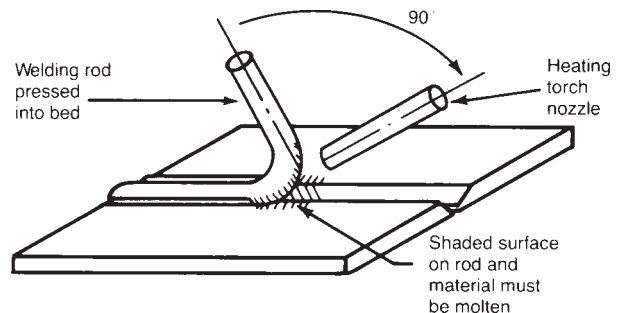

- 5) Continue welding at a steady and uniform rate of about 1/2–2 in/min.
- 6) Temperature, welding speed, rod pressure, and gas flow may be adjusted to vary from the indicated values as more skill and proficiency is achieved through experience.

Transparent Butt Seal

It has been demonstrated that an optically clear butt seal is possible by profile heating and cooling techniques (see Illustration C). By selectively heating and cooling a continuous metal surface in contact with the butt ends of DuPont FEP fluoro-carbon film, the film will flow and fuse to itself to give an optically clear seal. Heating the center portion of the metal where it is in contact with the butt ends and keeping the majority of the film on either side of the heated area cool restricts the thinning out and distortion of the film.

Illustration C. Transparent Butt Seal

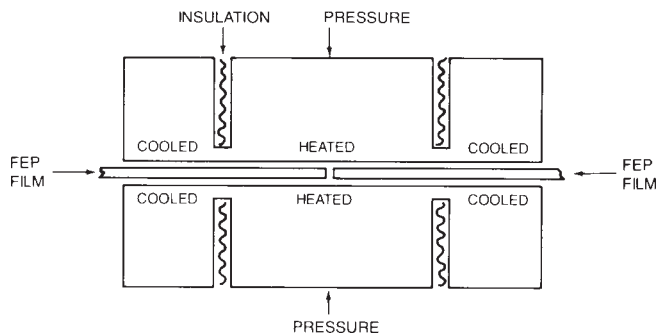

Other Methods of Sealing

Induction Sealing

FEP film can be heat sealed by induction heating of metal or metal oxides at the bond interface.

With induction heat sealing, metal or metal oxide is introduced at the bond interface. Heat is developed by energizing the magnetically excitable material with high-frequency induction generating equipment. The magnetic field passes through the films and generates heat at the bond interface. This eliminates the need for heat transfer through the thickness of the film.

Variables affecting the sealing rate are the type of metal used, its mass, and distance from the induction heating coil. Magnetic ferrous materials are best because of their intense hysteresis loss. Non-magnetic metals like aluminum, copper, tantalum, and nickel have been induction heated, but higher power input and longer dwell time is required.

Blends or electromagnetic energy absorbing materials and a thermoplastic of the same composition as the materials to be bonded are commercially available in tape form or injection molded shapes.

The tape or shape is placed between the sections to be joined (see Figure 7) and magnetically excited. Coil designs provide the intense magnetic field needed. The actual weld is DuPont FEP. If a low metal content is used, you can still obtain a true melt bond between the two FEP surfaces. This is extremely important for chemical applications.

Figure 7. Lap Weld Specimen



Heat Sealing Parameters

	Induction	Impulse
	Max. Film Thickness	0.500 in or more
Sealing Cycle	3 sec—60-mil	6 sec—20-mil
Appearance	No distortion	Some distortion and thinning*
Pressure	3–4 psi	20–40 psi

*Vertrod two-step impulse system gives smooth seal.

Ultrasonic Sealing

DuPont FEP fluorocarbon film may be ultrasonically sealed. Evaluation of any application for ultrasonic assembly must start with analysis of the part size, shape, and structure to determine ease of matching the ultrasonic tooling for efficient transfer of the sonic vibration without energy losses.

Mastersonics* is one manufacturer of equipment that has been effective in ultrasonically sealing DuPont FEP films.

Heat Bonding

DuPont FEP Fluorocarbon Film to Various Substrates

DuPont FEP fluorocarbon film is melt processible. Therefore, it can be heat bonded to many substrates (e.g., metals, glass cloth, and other high-temperature materials) without using adhesives. In this way, the unique properties of FEP film expand the functionality of the substrate. The substrate material often adds strength and rigidity to the FEP film.

Laminates can be produced in a platen press or on continuous laminating equipment. The general-purpose Type A film or the cementable Type C film may be used. Bonding is accomplished above the melting point of FEP (approximately 271°C [520°F]).

Good bonding to any substrate requires intimate surface contact between the substrate and the FEP film. The molten FEP must flow into the substrate's surface. The substrate must be free from surface contaminants.

Surface Treatment of Metals

FEP is quite viscous in the melt, which can impede intimate surface contact with the substrate. Methods of overcoming this are: raising the temperature of the melt to reduce viscosity or increasing laminating pressure to improve flow. However, the surface condition of a metal substrate can greatly influence bonding and dictate temperature and pressure conditions. Sandblasting, chemical etching, or rough grinding increases the effective surface area and "opens up" the surface. On a microscopic scale, a

metal's surface is like a mountain range. These surface roughening treatments increase the distance between peaks or widen the valleys. Thus the surface is "open" to the viscous flow of the molten FEP, facilitating intimate contact. The increased surface area also enhances bond strength. These techniques usually remove loose oxides, which, although they may bond to the FEP, have poor bond strength to the metal itself. Many metals are processed using oily lubricants. For this reason, it is wise to degrease the metal surface with solvents. Certain metals (copper in particular) rapidly form oxides at the temperatures recommended for bonding. The use of surface-treated copper is recommended.

Some materials, such as nickel, gold, and aluminum, do not yield strong bonds to Type A FEP film at temperatures under 316°C (600°F). However, Type C FEP film does produce good bonds in that temperature range. Indeed, a few materials will not bond at all to Type A film, but bond well to the Type C surface. It is also possible to bond Type C film to some materials below the melt range of FEP.

Typical platen press conditions and substrate treatments are given in **Table 1**.

DuPont FEP Fluorocarbon Dispersion Priming of Metals

Materials such as stainless steel or very thin foils may not respond readily to physical or chemical etching. Excellent bonds can be obtained by priming such surfaces with a thin coating of a fused DuPont FEP fluorocarbon dispersion. When using the primers, the following procedures are recommended:

1. Spray a very light coating of a mixture of 50% TFE Primer—#850-line and 50% FEP Dispersion #120** on the clean metal surface.
2. Fuse the coating in a forced draft oven at 371°C (700°F) for 5–10 min depending upon the mass of metal involved.
3. Laminate DuPont FEP fluorocarbon film to the primed surface at 288°C (550°F).

*Mastersonics, Granger, IN

**Available from the DuPont Company

Table 1
Typical Platen Press Conditions

Substrate	Interface Temperature, °C (°F)	Pressure, psi	Dwell Time, min	Substrate Surface Preparation and Treatment
Aluminum	282 (540) 293 (560)	100 100	5 5	None, if Type C film is used Parker Bonderite 700 series*
Copper	282 (540)	100	3–5	Various treatments
Steel	293–304 (560–580)	100–300	5	Sandblast and degrease, phosphatized*
Stainless steel	360 (680) 293 (560)	300 300	5 5	None Dispersion primer of Teflon®—see paragraph above
Teflon® TFE	343 (650)	100	3–5	None
Nickel	282 (540)	100	5	None, if Type C film is used
Nickel Ceramics Nichrome	293 (560)	300	5	Dispersion primer of DuPont FEP
Nomex® nylon paper	282 (540)	100	5	Use Type C film Pre-dry Nomex® (at 121°C [250°F], 30 min)
Glass	296 (565)	10	10	Silane coupling agent**
Kapton® polyimide film	282 (540)	100	5	None, if Type C film is used

*Treating and phosphating chemicals are available from Oxy Metal Industries, 322 Main St., Morenc, MI 49056.

**Silane coupling agents are available from Union Carbide Corporation and Dow Corning.

Platen Press Laminating

Hot platen press laminating is the most common technique for bonding DuPont FEP fluorocarbon film to other materials. There are a few fundamental considerations that contribute to good results with this technique. These are:

- Good platen temperature control and distribution ($\pm 5.5^{\circ}\text{C}$ [$\pm 10^{\circ}\text{F}$] across the laminating area).
- Even pressure distribution across the laminating area. Use a pressure pad (see **Figure 8**).
- Compensating pressure control. (The selected laminating pressure should be maintained regardless of expansion or contraction of the materials being laminated.)
- Use the minimum temperature, time, and pressure combination that produce desired results.
- Cool laminate to at least 204°C (400°F) before releasing pressure. This may be done by quickly transferring laminate to a cold press or quenching it in cold water.

Figure 8. Platen Press Laminating

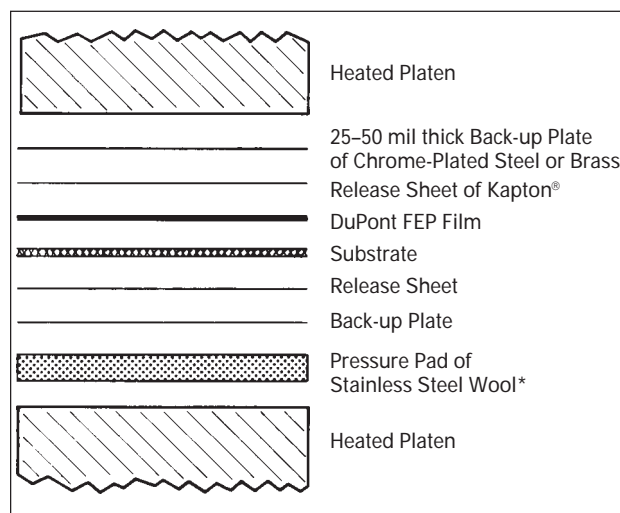

* Available from the International Steel Wool Corp.

DuPont FEP Fluorocarbon Film as an Adhesive

DuPont FEP fluorocarbon film is thought of usually as a release or antistick material. It is thought of occasionally as an inert thermoplastic from which various parts and shapes of pure FEP can be formed. Rarely is it thought of as an adhesive—yet its performance in all three of these areas is equally outstanding. It may be surprising to know that, when melted, DuPont film actually becomes an excellent adhesive for bonding many materials—metals and nonmetallics as well.

Few adhesives can match the broad capabilities of DuPont FEP film. Its excellent resistance to both chemicals and high temperatures makes possible bonded structures suitable for service in applications where ordinary adhesives may not be equal to the task. FEP film is a flexible adhesive that permits laminated structures to be post-formed. It is the ideal adhesive for TFE and produces strong bonds between two surfaces of PTFE or between PTFE and other substrates that can withstand temperatures greater than 332°C (630°F) (above the PTFE melt temperature). Because it is available in film form, on a roll, and in a range of thicknesses from 1/2–190 mil, Teflon® film is more convenient in handling and storing than many other adhesives.

Adhesive Laminating

DuPont FEP fluorocarbon film extends the DuPont family of films to those applications requiring high temperature resistance, antisticking surfaces, low coefficient of friction, and resistance to chemical attack. FEP film, Type C, has a specially treated surface that permits it to be used with conventional adhesives. Type A film is not as modified, and most adhesives will not adhere to it. However, the Type A film surface may be chemically etched to promote adhesion.

FEP film, Type C or etched, can be laminated to many heat-sensitive substrates (elastomers, fabrics, wood, plastics, and papers) using conventional laminating equipment. Irregular shapes can be fabricated using adhesive laminations of DuPont FEP film and post-forming techniques.

Many materials, by virtue of their adhesive character, may be combined with DuPont FEP film by casting or molding directly to the etched surface. Included in this category are most epoxy compounds, elastomers, urethane foam, uncured rubber, and some vinyl plastisols.

In most cases, the bond may be enhanced by a pretreatment of the substrate, although in the case of fabrics, wood, and other porous materials, this is unnecessary. The specific type of treatment required varies with the substrate used: thus, while metals may be treated with chemical etches or sandblasting, certain plastics may require only a solvent wash to remove surface contamination or plasticizer.

As mentioned above, FEP fluorocarbon film, Type C, manufactured by DuPont is modified with a proprietary surface treatment that allows it to be bonded using most commercial adhesives. Prolonged exposure of this specially treated surface to ultraviolet radiation, moisture, or elevated temperature will adversely affect cementability of the film.

Cementability tests have been carried out on unopened archive sample rolls of treated films. The results of these tests suggest that the adverse effect on cementability can be minimized by keeping the film in its original package or otherwise effectively protecting the film from ultraviolet light. For best results, it is advisable to carry out cementability tests on film prior to its use.

Laminating technique varies with the substrate and adhesive system employed. Most adhesive suppliers are familiar with the condition employed when bonding FEP film to various substrates and will have specific recommendations. When contacting adhesive suppliers for specific recommendations for a specific end-use application, it is suggested that the following information be supplied in the initial inquiry:

Process Limitations

- Maximum laminating temperature available.
- Maximum laminating pressure.
- Maximum time, heat, and pressure that can be applied to the laminate (drying tunnel, roll storage).
- Speed of laminator (if continuous process).
- Whether aqueous or organic solvent systems are preferred.
- Type of substrate.
- Type of adhesive applicator (reverse roll, gravure, flexographic).

End-use Conditions

- Maximum continuous use temperature.
- Maximum intermittent temperature.
- Degree of flexibility or formability needed.
- Bond strength needed (peel or shear).
- Type of atmosphere (chemical, humidity, outdoor).

Metallizing

DuPont FEP fluorocarbon film makes an excellent substrate for vacuum metallization—by either thermal evaporation or magnetron sputtering. Key properties are:

- Negligible moisture content
- Absence of additives and oligomers to outgas under vacuum and processing temperatures
- Inert to chemical reaction while in the metallizer
- Uniform film web thickness
- Good dimensional stability (low shrinkage)
- Resistance to degradation at metallizer temperature and pressure

As in the case for laminating, the film surface may have to be treated (Type C or sodium etched) to improve surface energy and enhance adhesion of the deposited metal particles. Untreated, general-purpose FEP film may be vacuum metallized for some applications depending upon the specific metal and deposition process used. Copper, aluminum, silver, gold, and some metallic oxides have been applied to DuPont FEP film through vacuum metallization.

Thermoforming of DuPont FEP Fluorocarbon Film

Introduction

DuPont FEP fluorocarbon film is a true thermoplastic material that is readily formable in either vacuum or pressure-forming equipment. Because it is available in thicknesses of 1/2–190 mil, DuPont FEP film can be used in a wide variety of applications from surfacing to completely self-supported structures. Its formability combined with its release properties, chemical inertness, and high service temperature make DuPont FEP film ideal for use in various antistick and corrosion-resistant surfacing applications.

Cementable film (treated or etched) may be adversely affected by thermoforming due to large area increases (stretched) and prolonged heat.

Vacuum Forming

Straight vacuum forming is adequate for most applications using 1/2-, 1-, 2-, and 5-mil films. It can also be used for thicker films where the mold is not too intricate. Modified vacuum forming techniques such as drape forming, use of a heated plug assist, and snapback forming are applicable. The heating time depends upon the distance of the film from the heaters and the complexity of the shape to be formed. As shown in **Table 2**, using a heater located 4 in above the film, a 10-sec heating time is optimum for forming 5-mil film in a 7 in × 12 in × 2 in female mold.

A radiant heater having a watt density of at least 3.5 kW/ft² is required to heat the film to the temperature where it can be formed. Most commercial equipment is supplied with heating elements of 1.7–2.5 kW/ft².

Molds for vacuum forming 10- and 20-mil DuPont FEP film should be heated to 93–149°C (200–300°F) in order to keep the film from cooling before it has been completely formed. In some cases, heated molds are helpful for forming thinner films also.

Table 2
Optimum Conditions for Vacuum Forming

Film Gauge, mil	Heat Density, kW/ft ²	Time, sec	Remarks
1	1.9	32	Only with rested heater
1	3.7	8	
2	3.7	10	
5	3.7	12	
10	3.7	20	Thick portion at point of initial contact with mold

Note: The mold used for this first set of data is a vertical cylinder 1 1/2 in high and 3 in diameter. It represents a 200% area increase.

Film Gauge, mil	Heat Density, kW/ft ²	Time, sec	Remarks
2	3.7	8	
5	3.7	10	
10	3.7	—	Heated in formed piece throughout time range. Heated mold necessary.
20	3.7	—	

Note: This mold is a pan-shaped cavity 7 in × 12 in × 2 in. It represents an area increase of 90%.

Pressure Forming

Pressure forming involves heating the clamped film with a contact platen mounted over the mold, then evacuating the mold cavity and simultaneously applying air pressure of 20–100 psi or greater to the upper side of the film.

Good conformity and detail are achieved with 1- to 20-mil DuPont FEP fluorocarbon film in such pressure forming equipment. Optimum platen temperatures range from 246°C (475°F) for 1-mil film to 254°C (490°F) for 5-, 10-, and 20-mil films. Above 257°C (495°F) the film tends to stick to the heater platen. At these temperatures, pressure requirements vary from 60–120 psi depending upon the thickness of the film.

Molds heated to 93–177°C (200–350°F) are required for pressure forming 10- and 20-mil DuPont FEP film. With 1-, 2-, and 5-mil films, the use of heated molds widens the forming temperature range from ±2.7 to 5.5°C (±5 to 10°F).

As shown in **Table 3**, a heating time of 10 sec is adequate for 1- to 20-mil film, although shorter heating time can be used with thinner films. The dwell time after forming is not critical, provided it is long enough to cool the film so that it can be removed from the mold without distortion.

Table 3
Optimum Conditions for Pressure Forming

Film Gauge, mil	Temp., °C (°F)	Heat Time, sec	Dwell Time, sec	Pressure, psi	Remarks
1	246 (475)	10	6	60	
2	252 (485)	10	6	60	
5	254 (490)	10	6	60	
10	254 (490)	10	7	80	Holes
20	254 (490)	10	6	100	

Note: The mold for the first set of data is a group of nine 3-in square pouches, 1 in deep. It represents an area increase of about 130% in each pouch. This mold has no heating.

Film Gauge, mil	Heat Temp., °C (°F)	Mold Temp., °C (°F)	Heat Time, sec	Dwell Time, sec	Pressure, psi
5	254 (490)	121 (250)	10	6	60
10	254 (490)	121 (250)	10	6	80
20	254 (490)	149 (300)	10	6	100

Note: The need for a heated mold is proved by the use of a disk shaped mold 4½ in diameter and 1 in deep heated with strap heater. Area increase is 87%.

Summary of Important Points

Thermoformable?

Yes—FEP is a true thermoplastic material that is readily formable.

Problems?

The major problem is when someone has difficulty in thermoforming FEP film, most of the time sufficient heat is not available (or if it's available, it's not made available long enough) to bring the film up to forming temperature.

What does it take?

It takes 3–3.5 kW/ft² watt density of radiant heat.

DuPont FEP film is very transparent to infrared energy and doesn't readily absorb the energy from radiant heaters. Ceramic heating elements have been successful in adequately heating DuPont FEP film for thermoforming.

The temperature of the heaters is usually above 649°C (1200°F) just to effectively heat the film to 260–288°C (500–550°F).

What does the FEP film do?

If there is sufficient heat intensity, the FEP film first wrinkles, buckles upward (against gravity, thermo-expansion, and relieving of stresses) and then tends to straighten out and finally free downward and continues to sag.

The FEP film will sag considerably and become crystal clear at the point when it should be formed, which is easily seen in 5-mil and above.

Minor wrinkles may occur at the first part of the heating cycle, but should even themselves out during sag.

One test of sufficient heat availability is that if heat is left on the FEP film, it will continue to sag indefinitely until it breaks from thinning out or touches something beneath it.

If it sags to a point and continued heating doesn't cause it to sag further, heat intensity is marginal.

Deep Draws

In deep draws, take advantage of the sag of the film. For instance, if you are forming a dome or cylinder, either form into a female mold or up over a male mold. Forming down over a male mold is more difficult (but not impossible) because you must turn the sag of the film inside-out.

Detailed Draws

Very good detail in the formed part is possible with DuPont FEP fluorocarbon film. To do so, the FEP film must be pulled tight against the mold while still hot (crystal clear).

Shrinkage

If the formed shape is stripped from the mold while hot, upon cooling some of the residual shrinkage will be removed. Thus, it will have less chance of fitting the mold again than if it was completely cooled while on the mold.

Webbing

Webbing can take place as the film is formed. It is related to mold design and caused by excess material not having a place to go; so it folds over on itself. This is most common with male molds in deep draws.

By placing a ring around the mold or small shapes at the points of webbing to take up the excess film, this foldover can generally be kept from occurring in the formed shape.

Mold Materials

Metals, TFE, and glass are the most frequently used mold materials. Plaster, wood, and lower temperature plastics may be used for several formed parts, if they are masked from the heating cycle, but may char under continued use.

Notes on Thermoforming

As in a molding operation, after cooling to room temperature, there will be shrinkage of the formed piece. The amount of the shrinkage will depend upon its temperature at the time of forming. A shrinkage allowance must be built into the mold. In the case of DuPont FEP film, the allowance will be 6–8% depending on expected temperatures of the film.

There will also be variable stresses in the piece due to the elongation of the film during the forming operation. These are not usually apparent until an

unrestrained piece is exposed to an elevated temperature, at which time stress relieving may distort the piece. This elongation stress can vary in amount in different sections of a formed piece and can also vary with different films used on the same mold. The film temperature/yield stress relationship will also have an effect. They can be “normalized” by using pressure-forming techniques at a temperature above that to which the restrained piece will be exposed.

Excessive thinning of film, at times to the point of rupture, can be experienced when forming in molds with a high ratio of depth to width of draw. A radius on the edges of the mold will help the film accommodate itself to the draw by making it easier to “flow” over a corner. Thickness of original film, its temperature, and rate of draw are also important.

An insulator such as TFE, glass, or wood (vs. a conductor such as metal) may offer some advantages in surface appearance. Many times a metal will give a finish with optical distortion in it, while TFE or wood will give less distortion to the part.

Mold Design

If the formed part has straight sides, try to design the mold so the formed part may be easily removed.

Forming into a female mold may offer advantages in removal vs. the tight fit of a formed shape over a male mold without tapered sides.

Vacuum Holes

Vacuum holes should be as small as practical: $\frac{1}{32}$ in maximum, $\frac{1}{64}$ in preferable.

Mold design may allow vacuum to be drawn through slits, a preferable method for gaining detail.

Vacuum holes should be located at strategic spots to pull the film in all crevices. Not every low spot or crevice must have a vacuum hole, but a sufficient number should be located to prevent any bridging of the film between high areas of the mold.

Most Commonly Used Forming Techniques

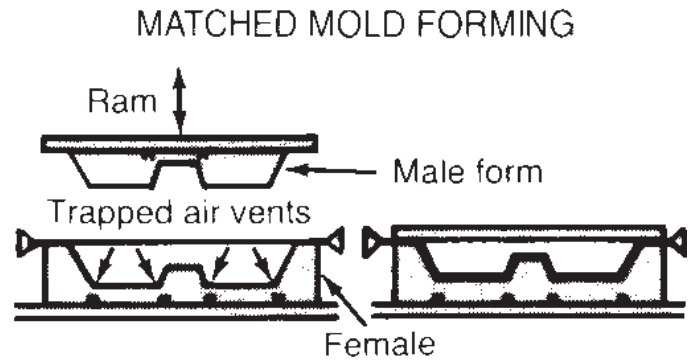
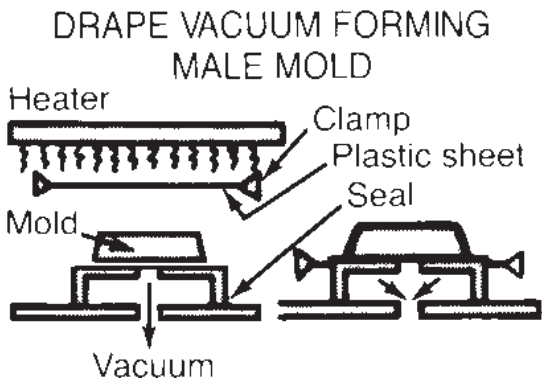
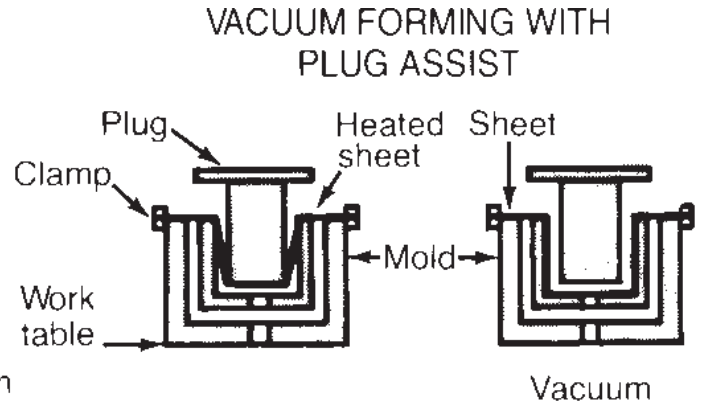
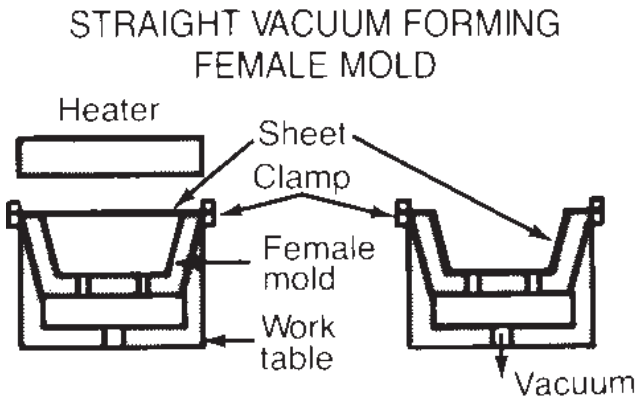

Less Frequently Used Techniques

PRESSURE FORMING w PLUG ASSIST
FEMALE MOLD

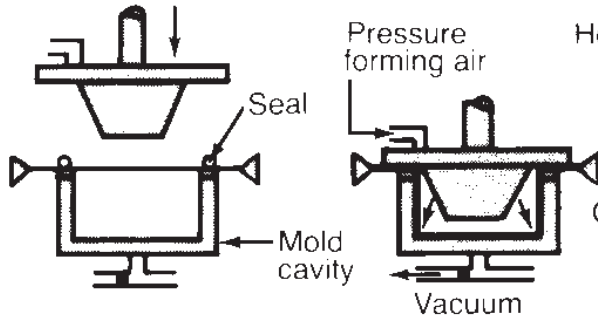

VACUUM SNAP-BACK FORMING

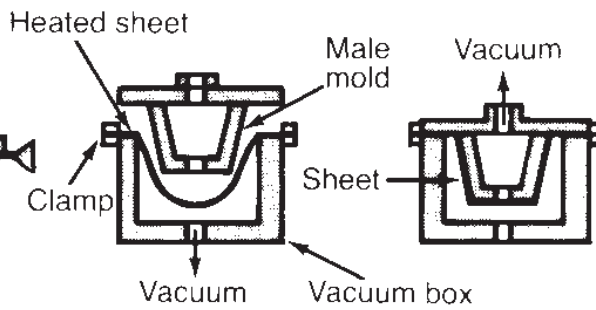

AIR-SLIP FORMING

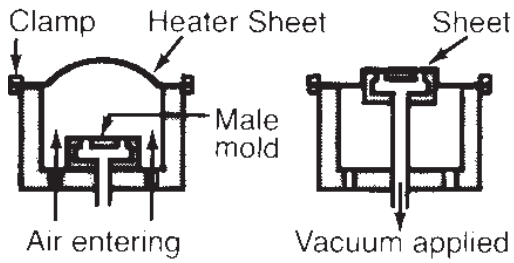

PRESSURE FORMING - FEMALE MOLD

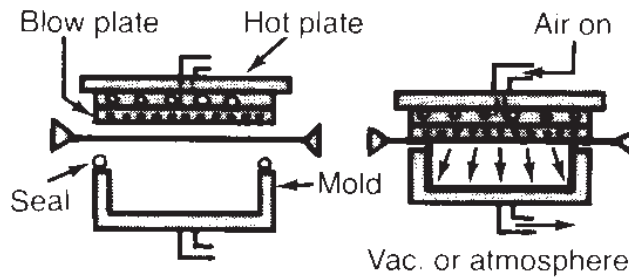

BLOWBACK FORMING WITH PRESSURE

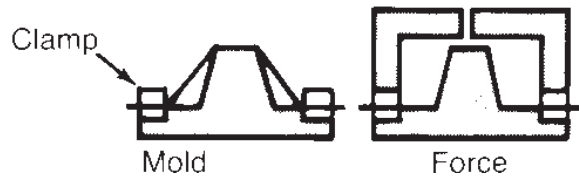

United States

DuPont High Performance Films
P.O. Box 89
Route 23 South and DuPont Road
Circleville, OH 43113
Ordering Information:
800-967-5607
Product Information:
800-237-4357
Fax: 800-879-4481

Canada

DuPont Canada, Inc.
P.O. Box 2200, Streetsville
Mississauga, Ontario, Canada
L5M 2H3
Inquiries: 905-821-5603
Customer Service: 800-263-2742
Fax: 905-821-5230

Latin America

Argentina

DuPont Argentina
Av. Mitre y Calle 5
CP 1884, Berazategui, Argentina
Pcia de Buenos Aires
54-1-256-2435
Fax: 54-1-319-4451

Brazil

DuPont do Brasil
Al. Itapecuru, 506
06454-080, Alphaville
Barueri, Sao Paulo
55-11-421-8689
Fax: 55-11-421-8686

Mexico

DuPont S.A. de C.V.
Homero 206
Col. Chapultepec Morales
Mexico, D.F. 11570
525-722-1184
Fax: 525-722-1370

Venezuela

DuPont Venezuela
Edificio "Los Frailes"
Calle la Guarita
Urbanization Chuao
CP 1060, Caracas, Venezuela
58-2-92-8547
Fax: 58-2-91-5638

Europe

DuPont de Nemours
(Luxembourg) S.A.
Contern
L-2984 Luxembourg
Grand Duchy of Luxembourg
352-3666-5575
Fax: 352-3666-5000

Asia Pacific

Japan

DuPont Kabushiki Katsha
Arco Tower
8-1, Shimomeguro 1-chome
Meguro-ku, Tokyo 153
Japan
81-3-5434-6139
Fax: 81-3-5434-6193

ASEAN

DuPont Singapore PTE Ltd.
1 Maritime Square
#07-01 World Trade Centre
Singapore 099253
65-279-3434
Fax: 65-279-3456

Hong Kong/China

DuPont China Ltd.
1122 New World Office Bldg.
East Wing
Salisbury Road, Kowloon
Hong Kong
852-2734-5401
Fax: 852-2721-4117

India

DuPont South Asia Ltd.
503-505, Madhava
Bandra Kurla Commercial Complex
Bandra (E)
Bombay 400 051
India
91-22-6438255/6438256
Fax: 91-22-6438297

Korea

DuPont Korea Ltd.
4/5th Floor, Asia Tower
#726, Yeoksam-dong, Kangnam-ku
Seoul 135-082, Korea
82-2-222-5398
Fax: 82-2-222-5476

Taiwan

DuPont Taiwan Ltd.
7, Tsu-Chiang 1st Road
Chungli, Taoyuan
Taiwan, ROC
866-3-4549204
Fax: 866-3-4620676



The information set forth herein is based on data believed to be reliable, but the DuPont Company makes no warranties express or implied as to its accuracy and assumes no liability arising out of its use by others. This publication is not to be taken as a license to operate under, or recommendation to infringe, any patent.

Caution: Do not use in medical applications involving permanent implantation in the human body. For other medical applications, see "DuPont Medical Caution Statement," H-50102.

